

# RP 系列 SERIES

- 3000h at 105°C
- high-reliability and professional applications
- RoHS Compliant

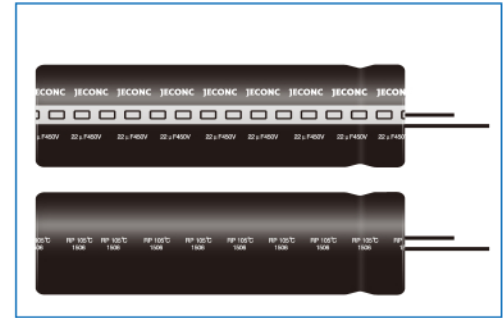

## ◆ SPECIFICATION

Items	Characteristics												
Operating Temperature Range (°C)	-25~+105°C												
Voltage range (V)	200~450v												
Capacitance Range (µF)	18~560 µF												
Capacitance Tolerance	±20% (at 20°C, 120Hz)												
leakage current (µA)	After 5 minute at 20°C application of rated voltage , leakage current is not more than: $I \leq 0.02CV + 25 \mu A$ C:Nominal Capacitance (µF)      V:Rated Voltage (V)												
Dissipation Factor(Tan δ)	<table border="1"> <tr> <td>WV (V)</td> <td>200</td> <td>250</td> <td>400</td> <td>420</td> <td>450</td> </tr> <tr> <td>Tan δ (max)</td> <td>0.15</td> <td>0.15</td> <td>0.2</td> <td>0.20</td> <td>0.20</td> </tr> </table> (at 20°C, 120Hz)	WV (V)	200	250	400	420	450	Tan δ (max)	0.15	0.15	0.2	0.20	0.20
WV (V)	200	250	400	420	450								
Tan δ (max)	0.15	0.15	0.2	0.20	0.20								
LowTemperature Characteristics	<table border="1"> <tr> <td>Rated Voltage (V)</td> <td>200~250</td> <td>400~450</td> </tr> <tr> <td>Z-25°C/Z+20°C</td> <td>3</td> <td>8</td> </tr> </table> (at 120Hz)	Rated Voltage (V)	200~250	400~450	Z-25°C/Z+20°C	3	8						
Rated Voltage (V)	200~250	400~450											
Z-25°C/Z+20°C	3	8											
Load Life	<p>The following specifications shall be satisfied when the capacitors are restored to 20°C after subjected to DCvoltage with the rated rippled current is applied for 3000 hours at 105 °C</p> <table border="1"> <tr> <td>Capacitance change</td> <td>Within ±20%initial value</td> </tr> <tr> <td>D. F. (Tan δ)</td> <td>Not more than 200% of specified value</td> </tr> <tr> <td>leakage current</td> <td>Not more thanspecified value</td> </tr> </table>	Capacitance change	Within ±20%initial value	D. F. (Tan δ)	Not more than 200% of specified value	leakage current	Not more thanspecified value						
Capacitance change	Within ±20%initial value												
D. F. (Tan δ)	Not more than 200% of specified value												
leakage current	Not more thanspecified value												
Shelf Life	<p>The following specifications shall be satisfied when the capacitors are restored to 20°C afterexposing them for 1,000hours at 105°Cwithout voltage applied .Before the measurement ,the capacitor shall be preconditioned by applying voltage according to Item 4.1 of JIS C 5101-4.</p> <table border="1"> <tr> <td>Capacitance change</td> <td>Within± 20%initial value</td> </tr> <tr> <td>D. F. (Tan δ)</td> <td>Not more than 200% of specified value</td> </tr> <tr> <td>leakage current</td> <td>Not more than 200% of specified value</td> </tr> </table>	Capacitance change	Within± 20%initial value	D. F. (Tan δ)	Not more than 200% of specified value	leakage current	Not more than 200% of specified value						
Capacitance change	Within± 20%initial value												
D. F. (Tan δ)	Not more than 200% of specified value												
leakage current	Not more than 200% of specified value												

## ◆ DIMENSIONS(mm)

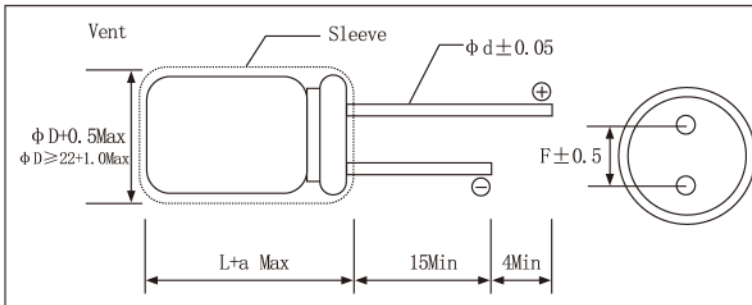

ΦD	10	13	16~18
F	5	5	7.5
Φd	0.6	0.6	0.8
a	2	2	2

## ◆ Frequency Coefficient

Frequency	50Hz	120Hz	1kHz	10kHz	100kHz	
	60Hz					
Coefficient	200~250V	0.8	1.0	1.20	1.30	1.40
	400~450V	0.8	1.0	1.25	1.40	1.50

## ◆ Temperature Coefficient

Temperature (°C)	+70	+85	+105
Coefficient	1.80	1.40	1.00

**RP** 系列  
SERIES

◆ STANDARD RATINGS

UR (Surge Voltage) Code	Rated Capacitance	Max Impedance 20°C120Hz	Rated Ripple Current 105°C120Hz	Size ΦD×L
(V)	(μF)	(Ω)	(mA rms)	(mm)
200 (250) 2D	82	2.42	400	10×30
	100	1.99	460	10×36
	120	1.66	530	10×40
	150	1.33	620	13×30
	180	1.11	700	13×36
	220	0.90	800	13×42
	270	0.74	870	16×36
	330	0.60	1010	16×40
		0.60	1010	18×32
	390	0.51	1130	18×36
	470	0.42	1270	18×40
250 (300) 2E	560	0.36	1390	18×45
	68	2.93	330	10×33
	82	2.43	420	10×40
	100	1.99	480	10×51
	120	1.66	560	13×36
	150	1.33	650	13×42
400 (450) 2G	220	0.91	840	16×40
	27	9.83	240	10×30
	33	8.04	280	10×36
	39	6.80	320	10×40
	47	5.65	370	13×30
		5.65	370	10×51
	56	4.74	420	13×36
	68	3.90	480	13×40
	82	3.24	520	13×51
	100	2.65	580	16×36
		2.65	580	13×51
	120	2.21	670	16×40
		2.21	670	18×36
	150	1.77	770	18×40
180	1.47	880	18×45	
420 (470) W6	22	12.06	200	10×30
	27	9.83	230	10×36
	33	8.04	270	10×40
	39	6.81	310	13×30
	47	5.65	360	13×36
		5.65	360	10×51
	56	4.74	430	13×40
		4.74	430	16×31
	68	3.90	490	16×36
		3.90	490	16×32
		3.90	490	13×42
	82	3.24	550	16×40
		3.24	550	16×36
		3.24	550	13×51
	100	2.65	610	16×40
		2.65	610	18×32
	120	2.21	660	18×36
150	1.77	710	18×45	
450 (500) 2W	18	14.74	180	10×30
	22	12.06	210	10×36
	27	9.83	250	10×40
	33	8.04	280	13×30
	39	6.81	320	13×36
		6.81	320	10×51
	47	5.65	380	13×40
		5.65	380	16×31
		5.65	380	10×51
	53	5.01	410	10×51
	56	4.74	440	16×36
		4.74	440	16×32
	68	3.90	510	16×40
		3.90	510	16×36
		3.90	510	13×51
	82	3.24	570	16×40
		3.24	570	18×32
		3.24	570	13×51